

অসম চৰকাৰ



सत्यमेव जयते

GOVERNMENT OF ASSAM

# PROSPECTUS 2024-2025



## পণ্ডিত দীনদয়াল উপাধ্যায় আদৰ্শ মহাবিদ্যালয় PANDIT DEENDAYAL UPADHYAYA ADARSHA MAHAVIDYALAYA, AMJONGA

(GOVERNMENT MODEL COLLEGE)

আমজোঙা, গোৱালপাৰা, অসম : ৭৮৩১২৪

Amjonga, Goalpara, Assam-783124

**Estd: 2017**

Phone: +91-8011082759

Email: modelcollegeamjonga@gmail.com

Website: www.pduamamjonga.ac.in

"Learning Never Exhausts the Mind"

"শিক্ষা আৰু সাধনাতহে প্রজ্ঞা প্রাপ্তি হয়"





## **Dr. Malina Devi Rabha**

President, GB, PDUAM, Amjonga  
Goalpara, Assam-783121

## **MESSAGE**

In the realm of higher and technical education, it is a real moment of pride and pleasure to announce the commencement of Pandit Deendayal Upadhyaya Adarsha Mahavidyalaya at Amjonga of Goalpara District in the year 2017. The college is an honest attempt at achieving the height of centre for Excellence in due course of time. Pandit Deendayal Upadhyaya Adarsha Mahavidyalaya at Amjonga is the outcome of the Model College establishment scheme of the Government of Assam in educationally backward Districts.

It is an earnest attempt to educate and empower each and every student from the socially and educationally backward regions or the state. It is hoped that this college would try to focus at imparting knowledge, skill based education and practical applicability and viability of science. Let us aspire for an overall growth and transcendental glory in future with Pandit Deendayal Upadhyaya Adarsha Mahavidyalaya, Amjonga.

Dated : 1<sup>st</sup> April, 2024

**(Dr. Malina Devi Rabha)**  
President, GB, PDUAM, Amjonga



## Welcome note from the Principal's desk...

**Dr. Navajyoti Sarmah**

**A**s the first Principal of Pandit Deendayal Upadhyaya Adarsha Mahavidyalaya, Amjonga, Goalpara, I welcome and extend my warm wishes to one and all. With the support of a dedicated staff (teaching as well as non-teaching) and the assistance of local inhabitants—whose intellectual and general growth is our primary focus—I hope, or rather, know that we would achieve and set many milestones in the coming years. It is our inability to provide state-of-the-art facilities that compels youngsters to move outside the state. PDUAM, Amjonga strives to fill in this gap. Let us all work together keeping in mind the need for quality education in science and technology. By our consistent efforts and hard work, let us give our students an institute that they would, one day, be proud to call their alma mater. We are fortunate and grateful enough for the introduction of ARTS Stream from the academic session of 2023-24 onwards by the Govt. of Assam. The college at present offers HS course in both Science and Arts and Four Years Under Graduate Programme (FYUGP) in Science and Arts under the Gauhati University. The college has been aiming at catering an overall development and growth of its students, ever since its inauguration in August, 2017 by the then Hon'ble Education Minister and the present Chief Minister of Assam, Dr. Himanta Biswa Sarma. The college has been organising various significant events and programmes such as Teacher's Day, Freshman's Social, Annual College Week, Saraswati Puja, Republic Day, National Science Day, World Environment Day, International Women's Day, celebration of Rongali Bihu with active participation of the students, teaching and non-teaching staff, parents and guardians and local inhabitants. We have been successfully organising various Certificate/Short- Term Skill-Based Courses for the greater interest and indulgence of our students. Our students have excelled in cultural, literary and sports events in the National, State and inter- District level competitions and have brought accolades to the institution. The Students' Union body actively organise various student related programmes and activities and the NSS Unit has been functioning in full-fledged manner. We are opening NCC Unit very shortly for the overall growth and advancement of the students.

The college has now a beautiful campus with modern and well-equipped Science Laboratories, Central Library, Smart Classrooms, Gymnasium, Health Centre, Girls' Hostel and PG for Boys to strengthen the college infrastructure and student support activities. We have published two issues of the PDUAM News Bulletin and a peer-reviewed international Research Journal is under the process of publication. We have been actively organising various seminars, workshops, popular talks for the welfare and progress of both the teachers and students from time to time. We have signed MoUs with many prestigious academic institutions, organisations for various student related programmes and activities which have been beneficial and pioneering indeed. We are hopeful to widen up the horizon of learning, impart knowledge and education for the students in coming days. A new academic building is under construction which will be available from the coming academic session to cater the growing need of the college with new classrooms. We are also setting up a permanent canteen in the college campus.

I thank our students for trusting us enough to place their futures in our hands. Dear student friends, it is ambition that propels one to action—set your goals high and work accordingly. As is said, always aspire for the moon and even if you fail, don't worry, you would fall among the stars. We sincerely assure you a compatible academic atmosphere in the college through quality and value-oriented education.

It is earnestly hoped to see many years of glory with PDUAM, Amjonga. Thank you.

**Principal**  
PDUAM, Amjonga, Goalpara.

# CONTENTS

	Page No.
1. Introduction	2
2. Vision of the College	2
3. Objective of the College	2
4. College at a Glance	2
5. Courses Offered	3
6. Category-wise Seat Allotment for HS 1st Year (Arts and Science)	3
7. Category-wise Seat Allotment for FYUGP 1st Year (Arts and Science)	3
8. Medium of Instruction	4
9. Admission Procedure	4
10. Admission Criteria for HS 1st Year (Arts and Science)	5
11. Combination of Subjects for HS 1st Year (Arts and Science)	5
12. Admission Criteria for FYUGP 1st Year (Arts and Science)	5
13. List of Prerequisites & Requirements for Core Courses in Arts Stream	6
14. List of Prerequisites & Requirements for Core Courses in Science Stream	6
15. The complete curricula for GU-FYUGP	6
16. Important Dates for Admission into Courses	8
17. Fee Structure (2024-2025)	9
18. Examination and Attendance Rules	11
19. Infrastructural Facilities	11
20. Scholarship	12
21. Academic and Co-curricular Activities	12
22. General Rules for Students' Code of Conduct	12
23. Important Information to Parents/Guardians	13
24. Regulations of FYUGP under NEP-2020	13
25. Different Committees and Cells	13
27. Information and Contact Numbers	16
28. Academic Calendar for the Session 2024-2025	18

## **INTRODUCTION**

Pandit Deendayal Upadhyaya Adarsha Mahavidyalaya was established at Amjonga in the district of Goalpara by the Government of Assam with the financial assistance from the Rashtriya Uchchatar Shiksha Abhiyan (RUSA). The institution was named after Pandit Deendayal Upadhyaya, a great thinker, philosopher and a renowned sociologist of the country. The government initiative to establish the college was to provide quality higher education compatible to one available in the best institutes of the country along with a distinct focus on science education, which is affordable and accessible to all sections of the society. The foundation of the college was laid on 29th October, 2014 and through continuous efforts of the Department of Higher Education and the RUSA, the institution has finally been able to open the gate for the first batch of students from the academic year 2017-18.

The college is located at Amjonga, a very beautiful and mesmerising tiny hamlet, about 7 kms. from Dudhnoi, the headquarter of Rabha Hasong Autonomous Council in Goalpara district. The college has an infrastructure built on a sprawling campus spreading over 25 bighas of land. The serene and the green campus of the college has the best ambiance including well-stocked library, digital classrooms, up to date laboratories conducive for teaching, learning and research along with residential facilities for college staff and girl students. Although the infrastructure of the college is yet to be completed, it is hoped that it will be completed soon by the sincere efforts of the concerned authorities. A galaxy of highly qualified and dedicated faculties put their best efforts to impart education by monitoring the students for their overall improvements. In addition to the existing Science Stream, the college received permission to introduce Arts Stream from the academic session 2023-24 onwards by the Govt. of Assam. At present, the college offers Higher Secondary course in both Science and Arts streams under Assam Higher Secondary Education Council (AHSEC) and an undergraduate programme (FYUGP) leading to Bachelors' Degree in Science (B.Sc.) and Arts (B.A.) under the Gauhati University. The college has an ambitious plan to introduce Post Graduate courses along with several Skill Development courses in the years to come.

### **VISION OF THE COLLEGE :**

- To make quality a defining element of higher education along with continuous and consistent quest.
- To develop the potential of the students to meet the aspiration and perception of the society and the nation through the acquisition of knowledge, skills and values.

### **OBJECTIVES OF THE COLLEGE :**

- Promoting holistic education and training that endows the student with skills required to sustain their career in competitive global arena.
- To develop human resource and capacity building to cater the need of the economy, society and the country as a whole, thereby contributing to the development of the nation.
- Quest for excellence to provide best of the best experiences in teaching and learning by promoting the use of ICT.
- To inculcate a value system amongst the students to generate social responsibility.
- Providing adequate opportunities of higher education to socially and educationally backward groups, like SC, ST, Women, OBC and MOBC, Minorities and differently abled persons.

## **College at A Glance**

Name	: Pandit Deendayal Upadhyaya Adarsha Mahavidyalaya.
Year of establishment	: 2017
Contact Details	: Vill. & P.O.: Amjonga, P.S.: Dudhnoi, District: Goalpara, Assam, PIN-783124
Phone	: +91-9435849434
Email	: modelcollegeamjonga@gmail.com
Website	: www.pduamamjonga.ac.in
Affiliation	: Gauhati University
Status of the College	: Government
No of Streams	: 2 (Arts & Science )
No of Total Departments	: 13
Arts	: Assamese, Economics, Education, English, History, Political Science, Sociology
Science	: Botany, Chemistry, Computer Science, Mathematics, Physics, Zoology
College office hours	: 9.00 AM to 4.00 PM (Monday to Friday), 9.00 AM to 2.00 PM (Saturday)
Visiting time for Principal	: Tuesday to Friday (11.00 AM to 1.00 PM)

## COURSES OFFERED :

1. Two Years H.S. Course in Arts & Science.
2. Four Years UG Programme in Arts & Science under Gauhati University.

### CATEGORY-WISE SEAT ALLOTMENT FOR H.S. 1st YEAR (ARTS & SCIENCE) :

Stream	UR 51%	OBC/MOBC 27%	ST (P) 10%	ST (H) 5%	SC 7%	Total seats
Arts	103	54	20	10	14	200
Science	103	54	20	10	14	200

### CATEGORY-WISE SEAT ALLOTMENT FOR FYUGP 1st YEAR (SCIENCE) IN MAJOR:

SN.	Subjects	Total seats in Major	UR 51%	OBC/MOBC 27%	ST (P) 12%	ST (H) 5%	SC 7%	Total seats
1	Physics	20	10	5	2	1	2	120
2	Chemistry	20	10	5	2	1	2	
3	Mathematics	20	10	5	2	1	2	
4	Computer Science	20	10	5	2	1	2	
5	Botany	20	10	5	2	2	2	
6	Zoology	20	10	5	2	2	2	

### CATEGORY-WISE SEAT ALLOTMENT FOR FYUGP 1st YEAR (SCIENCE) IN MINOR :

SN.	Subjects	Total seats in Minor	UR 51%	OBC/MOBC 27%	ST (P) 12%	ST (H) 5%	SC 7%	Total seats
1	Physics	40	20	10	4	2	4	240
2	Chemistry	40	20	10	4	2	4	
3	Mathematics	40	20	10	4	2	4	
4	Computer Science	40	20	10	4	2	4	
5	Botany	40	20	10	4	3	6	
6	Zoology	40	20	10	4	3	6	

### CATEGORY-WISE SEAT ALLOTMENT FOR FYUGP 1st YEAR (ARTS) IN MAJOR :

SN.	Subjects	Total seats in Major	UR 51%	OBC/MOBC 27%	ST (P) 12%	ST (H) 5%	SC 7%	Total seats
1	Assamese	70	36	19	7	3	5	390
2	English	70	36	19	7	3	5	
3	Sociology	50	26	13	5	3	4	
4	Economics	50	26	13	5	3	4	
5	Education	50	26	13	5	3	4	
6	History	50	26	13	5	3	4	
7	Pol. Science	50	26	13	5	3	4	

## CATEGORY-WISE SEAT ALLOTMENT FOR FYUGP 1st YEAR (ARTS) IN MINOR :

SN.	Subjects	Total seats in Minor	UR 51%	OBC/MOBC 27%	ST (P) 12%	ST (H) 5%	SC 7%	Total seats
1	Assamese	280	142	76	28	14	20	1310
2	English	280	142	76	28	14	20	
3	Sociology	150	76	40	15	8	11	
4	Economics	150	76	40	15	8	11	
5	Education	150	76	40	15	8	11	
6	History	150	76	40	15	8	11	
7	Pol. Science	150	76	40	15	8	11	

### MEDIUM OF INSTRUCTION

Assamese and English

### ADMISSION PROCEDURE

- Higher Secondary (Arts & Science) B.A. / B. Sc. 1st Semester admission for new Academic Year, 2024-2025 will be started immediately after the declaration of HSLC/HS result.
- Admission Form for the college will be available in the office of the Principal.
- Admission into the college is made strictly in order of merit and is governed by the college admission rules. The Principal's decision regarding admission is final.
- A student can opt for only those subjects in FYUGP in which he/she has passed in H.S. without grace marks.
- A candidate must produce the following documents in original at the time of admission.
  - Mark Sheet and Admit Card of the last qualifying examination.
  - Age Certificate/ HSLC Admit Card.
  - Character Certificate from the head of the Institution last attended.
  - Two copies of recent passport size photograph.
  - Caste Certificate from competent authority (wherever applicable).
  - Certificate for differently abled (wherever applicable).
  - Certificate/Documents for co-curricular activities (only state and national level certificate will be entertained).
  - Gap Certificate (wherever applicable)
  - Unique Id (Created from D.H.E.)
  - Bank Pass Book ( Xerox)
  - ARN No for H.S. Students (Created from Darpon Portail)
  - Pan Card and Aadhar Card
  - Income Certificate
- All candidates must submit self-attested copies of (a), (b), (c), (d), (i), (j), (k), (l), (n) from the above at the time of application. Students belonging to SC, ST(P), ST (H), OBC and MOBC categories must also submit an attested copy of (e). Students who want to avail (f), (g) and (h) must furnish suitable documents at the time of application.
- Incomplete form or form without documents will be rejected.
- No form will be accepted after the last date of submission under any circumstances.

#### ***N.B. Gap Certificate must be issued from any one of the following:***

- Head of the Institution last attended.
- Officer in-charge of the nearest police station.
- Government Gazetted officer testifying his/her activities during the intern period.
- Medical Certificate from govt. registered Medical practitioner on genuine medical grounds.



### **ADMISSION CRITERIA FOR H.S. 1<sup>ST</sup> YEAR (ARTS) :**

HSLC with minimum 45% of marks for General Category / 40% of marks for SC Category / 42% of marks for OBC/MOBC Category / 35% of marks for ST Category.

### **ADMISSION CRITERIA FOR H.S. 1<sup>ST</sup> YEAR (SCIENCE) :**

HSLC with minimum 50% of marks for General Category / 45% of marks for SC Category / 47% of marks for OBC/MOBC Category / 40% of marks for ST Category.

### **COMBINATION OF SUBJECTS :**

#### **Compulsory Subjects for Arts and Science:**

- a. English
- b. MIL -Assamese or Alternative English ( Bodo self study)
- c. Environmental Studies (in first year only)

#### **Elective Subjects for Arts Stream**

A student must select three/four elective subjects from the following list:

- |                |                      |              |
|----------------|----------------------|--------------|
| a. Economics   | b. Education         | c. History   |
| d. Mathematics | e. Political Science | f. Sociology |

#### **Elective Subjects for Science Stream :**

A student must select three/four elective subjects from the following list:

- |                |              |                     |
|----------------|--------------|---------------------|
| a. Biology     | b. Chemistry | c. Computer Science |
| d. Mathematics | e. Physics   |                     |

**Note :** As per AHSEC regulation, a student opting Computer Science as an elective subject in Science stream shall have to opt Mathematics and two other elective subjects. i.e. such a student shall have four elective subjects.

### **ADMISSION CRITERIA FOR FOUR YEAR UNDER GRADUATE PROGRAMME (FYUGP) IN ARTS :**

1. HS Final Examination Passed.
2. Admission to the FYUGP will be based on the preference of Major, if any. In case a student does not want to opt for any Major, he/she will be admitted on the basis of preferences of the subject combinations.
3. Admission to a Programme or Major will be subject to availability of the subject and capacity of a college / department.
4. No student shall be eligible for admission to a Programme in any discipline under the FYUGP unless she/he fulfills the pre-requisites of courses as fixed by the university.

### **ADMISSION CRITERIA FOR FOUR YEAR UNDER GRADUATE PROGRAMME (FYUGP) IN SCIENCE :**

1. HS Final Examination Passed in Science.
2. Admission to the FYUGP will be based on the preference of Major, if any. In case a student does not want to opt for any Major, he/she will be admitted on the basis of preferences of the subject combinations.
3. Admission to a Programme or Major will be subject to availability of the subject and capacity of a college / department.
4. No student shall be eligible for admission to a Programme in any discipline under the FYUGP unless she/he fulfills the pre-requisites of courses as fixed by the university.

**LIST OF PREREQUISITES & REQUIREMENTS FOR CORE COURSES IN ARTS STREAM :**

Subjects	Prerequisites	Requirements
Assamese	Assamese (X-Level) for Minor and Assamese (XII-Level) for Major	None
English	English (X-Level)	
Sociology	None	
Political Science	None	
Education	None	
Economics	None	
History	None	

**LIST OF PREREQUISITES & REQUIREMENTS FOR CORE COURSES IN SCIENCE STREAM :**

Subjects	Prerequisites	Requirements
Botany	Biology (XII-Level)	Chemistry
Chemistry	Chemistry and Mathematics (XII-Level) for Major and only Chemistry (XII-Level) for Minor	None
Computer Science	Science and Mathematics(XII-Level)	None
Mathematics	Mathematics(XII-Level)	None
Physics	Physics and Mathematics(XII-Level)	Mathematics
Zoology	Biology and Chemistry (XII-Level)	Chemistry

**Note :** A candidate who opts for a subject in column (2) must have passed the corresponding subjects in column (3) in the 10+2 or equivalent examination.

**THE COMPLETE CURRICULA FOR GU-FYUGP ARE AS FOLLOWS:**

**Degree with Major and Minors:**

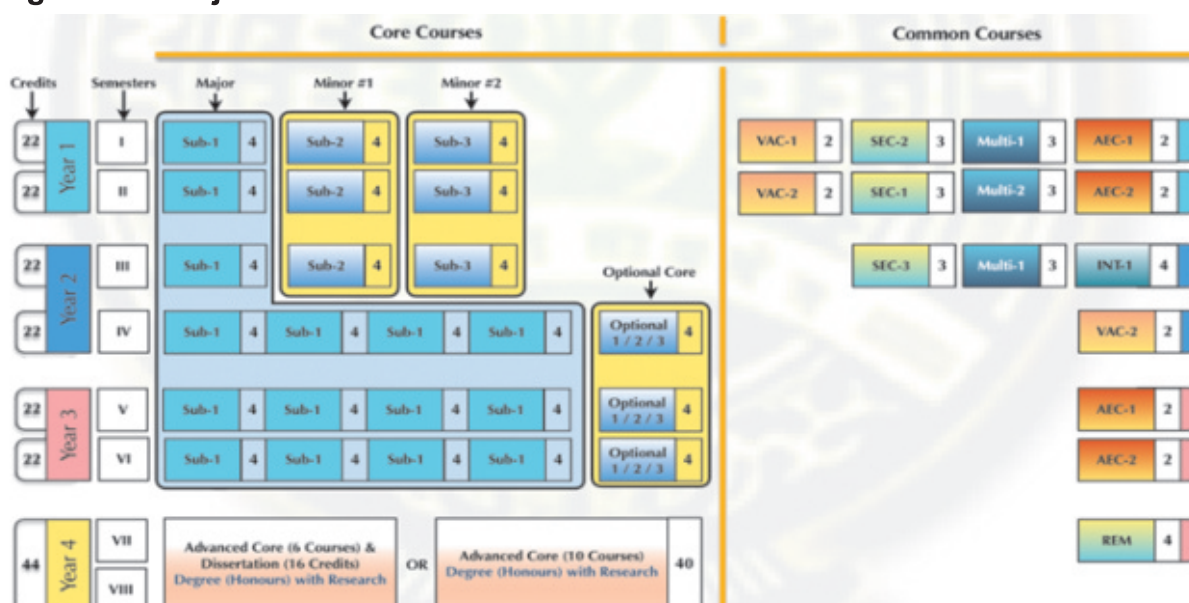

## Degree with only Minors:

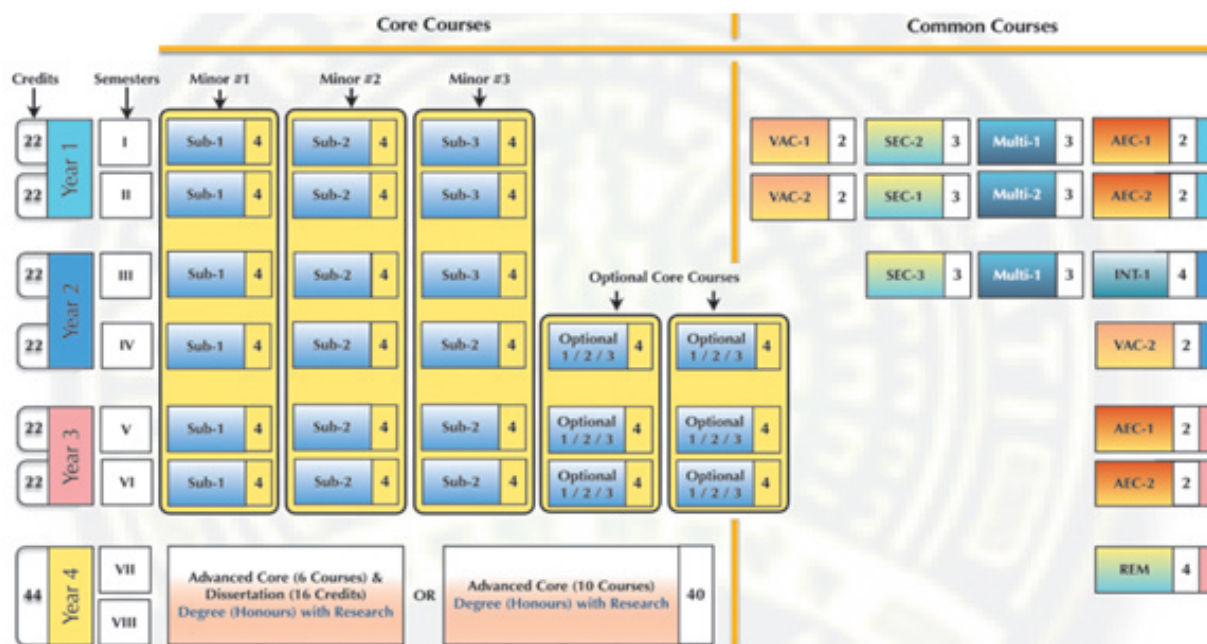

– Skill Enhancement Course

**Multi** – Multidisciplinary Course

**AEC** – Ability Enhancement Course

**INT** – Internship

**REM** – Research Methodology

**Value Added Courses (VAC):** The VAC courses will come from four sub groups — (i) Understanding India, (ii) United Nations and Human Rights, (iii) Environmental Science, (iv) Digital and Technological Solutions, and (v) Health & Wellness, Yoga Education, Sports, and Fitness. All together they will have a credit allocation of 6.

Each student will have to take any three courses, each of 2-credit, from any three groups during Semesters 1, 2, & 4. Here one course from the Environmental Science group is compulsory except if the student takes a core course on Environmental Science.

**Skill Enhancement Courses (SEC):** These are various skill courses with total credit allocation of 9. All students need to complete three skill courses, each with 3 credits during Semesters 1-3.

**Multi-disciplinary:** These are 3-credit courses spanning over five different groups of subjects — (i) Natural and Physics Science, (ii) Mathematics, Statistics, and Computer Applications, (iii) Library, Information, and Media Sciences, (iv) Commerce and Management, and (v) Humanities and Social Sciences. The level of these courses are of Class XII. Each student need to take at any three papers, each with 3-credits from these five sub-groups during Semesters 1-3.

### Courses Key Points:

1. A student CANNOT choose a multidisciplinary subject, if s/he has already studied that subject during Class XI-XII.
2. Also the subject of these courses MUST not be among the Core Subjects the student has already chosen.

**Ability Enhancement Courses (AEC):** This is an 8-credit course covering Modern Indian Languages (MIL) and English Usage (Communication).

**Internship:** All student are to carry out an Internship with a credit allocation of 4. The internship can be carried out in any semester during Semesters 3-6. As internships are meant to be done during semester breaks, they will not interfere with other classes.

### The fourth year:

In the FYUGP, the fourth year is at par with the first year of a Master's programme, as a student can directly can take admission into the second year of a Master's programme after the successful completion of the FYUGP.

In the fourth year, a student has to complete one compulsory paper on Research Methodology (REM) in the Semester VII, which is a 4-credit theory paper. The rest of courses will consist of Advanced Core Courses and a Dissertation. The detailed structure for the fourth year will be published soon.

**N.B. For more details see the NEP-2020 Information Booklet for FYUGP.**

**IMPORTANT DATES FOR ADMISSION INTO COURSES :**

SN	Courses	Issue of Form and Prospectus	Last Date of Submission of Forms	Notification and Display of Selected list of Candidates	Date of Interview and Admission
01	HS 1 <sup>ST</sup> YEAR (ARTS & SCIENCE)	.....April, 2024	Within 1 week after declaration of HSLC Result	To be notified in college website and notice board	To be notified in college website and notice board
02	B.A. & B.Sc. 1 <sup>ST</sup> YEAR Semester	Do	Within 1 week after declaration of HS Result	Do	Do

*”Real education enhances the dignity of a human being and increases his or her self-respect. If only the real sense of education could be realized by each individual and carried forward in every field of human activity, the world will be so much a better place to live in.”*

*- APJ Abdul Kalam*

## FEE STRUCTURE

### A. New fees structure for Higher Secondary

Govt order No: Ecf No. 313198

Dated: kahilipara, 10-07-2023

Sl No	Head	Sub -Head	Arts	Science
01	Assam Higher Secondary Council Fee	Registration Fee	150.00	150.00
		Enrolment Fee	50.00	50.00
02	Establishment	Renovation & Repairing old building	100.00	100.00
		Desk Bench and College furniture	100.00	100.00
		Computer Purchase & Annual Maintenance	80.00	80.00
		Toilet repairing & Cleaning	50.00	50.00
		Boys & Girls Common Room	50.00	50.00
		CCTV & Security	100.00	100.00
		Campus beautification, Gardening Internal Road and Disaster fund	50.00 100.00	50.00 100.00
03	Laboratory	Equipments, Chemical, etc	Nil	100.00
04	Electricity	Power	300.00	300.00
		Generator, Fuel, Fan-Bulb Purchase & Repairing	200.00	200.00
05	Library	New Book purchase	200.00	200.00
		Library & Lib. Software updating	100.00	100.00
06	Contingency	Stationary, TA for Council	400.00	400.00
07	Development	Academic Seminar	100.00	100.00
		Soft & hard skill Development	50.00	50.00
		Sports facility & Training	50.00	50.00
		Cultural facility and workshop	50.00	50.00
08	Continuous Evaluation	Examination	200.00	200.00
09	Students related Fee	NCC/NSS/Scout/Red Cross	50.00	50.00
		I Card	50.00	50.00
		Magazine	100.00	100.00
		Union Fee	50.00	50.00
		Games & Sports competition	50.00	50.00
		Festival	50.00	50.00
		Culture & drama and Music	100.00	100.00
		Debate	100.00	100.00
		Youth Festival	100.00	100.00
		<b>Total</b>	<b>₹ 3150.00</b>	<b>₹ 3330.00</b>

## FEE STRUCTURE

### B. New fees structure for UG course

Govt order No: Ecf No. 313198

Dated: kahilipara, 10-07-2023

SI No	Head	Sub -Head	Arts	Science
01	University Fee	Affiliation & Inspection Fee	2000.00	200.00
		Registration Fee ( For 1st Year only)	430.00	430.00
		Enrolment Fee	250.00	250.00
02	Establishment	Renovation & Repairing old building	100.00	100.00
		Desk Bench and College furniture	100.00	100.00
		Computer Purchase & Annual Maintenance	80.00	80.00
		Toilet repairing & Cleaning	50.00	50.00
		Boys & Girls Common Room	50.00	50.00
		CCTV & Security	100.00	100.00
		Campus beautification, Gardening	50.00	50.00
		Internal Road and Disaster fund	100.00	100.00
03	Laboratory	Equipments, Chemical, etc	Nil	900.00
04	Electricity	Power	300.00	300.00
		Generator, Fuel, Fan-Bulb Purchase & Repairing	200.00	200.00
05	Library	New Book purchase	200.00	200.00
		Library & Lib. Software updating	100.00	100.00
06	Contingency	Stationary, TA for University	400.00	400.00
07	Development	Academic Seminar	100.00	100.00
		Quality (NAAC)	100.00	100.00
		Faculty	100.00	100.00
		Guest Lecturer	50.00	50.00
		Soft & Hard skill Development	50.00	50.00
		Sports facility & Training	50.00	50.00
		Cultural facility and workshop	50.00	50.00
08	Continuous Evaluation	Examination	200.00	200.00
09	Students related Fee	NCC/NSS/Scout/Red Cross	50.00	50.00
		I Card	50.00	50.00
		Magazine	100.00	100.00
		Union Fee	50.00	50.00
		Games & Sports competition	50.00	50.00
		Festival	50.00	50.00
		Culture & drama and Music	100.00	100.00
		Debate	100.00	100.00
		Youth Festival	100.00	100.00
<b>Total</b>			<b>₹ 4060.00</b>	<b>₹ 4960.00</b>

## **SCHEME FOR WAIVER OF ADMISSION FEE FOR STUDENTS TAKING ADMISSION IN HS FIRST YEAR AND B.A/ B.Sc. FIRST SEMESTER**

As per the order of the Government of Assam, the college has decided to waive the fees, including admission and tuition fees for HS 1st year and TDC 1st year College Students belonging to economically backward families whose parent's annual income is less than Rs 2 lakh. To avail the scheme, the parental income of the student be less than Rs 2 lakh from all the sources. If either of the parents (mother or father) of the student is working in the State Govt/ Central Govt/ Semi Govt/ State or Central Govt undertakings, such students shall not be eligible under this scheme.

### **PROOF OF INCOME/ DOCUMENTS REQUIRED**

- (a) An Income Certificate from the local Revenue Circle Officer or Mauzadar.
- (b) A declaration from the students that neither of the parent (father or mother) of the student is an employee of State/Central Govt. Department or its undertaking.

### **DUTIES AND RESPONSIBILITIES OF STUDENTS AVAILING THE SCHEME:**

Students seeking admission into 1st year will plant a sapling at his/her College or at his/ her home and shall submit photograph of the same to the college. The student has to nurse the sapling and while seeking admission into second year shall submit photograph of the same tree that was planted during previous year.

### **EXAMINATION AND ATTENDANCE RULES :**

- It is compulsory for the students to appear in all the examinations conducted by the College during per academic sessions.
- For HS students, the college conducts Unit Tests in the middle of the session and Test examinations after completion of the entire syllabus.
- For B.A/ B.Sc. students, there are two Sessional Examinations per year, one for each semester. It is mandatory to appear in the Sessional Examinations without fail as the marks secured will be added in the Final Examination.
- Students must attend their classes regularly. At least 75% attendance in class is compulsory failing to which the student will be declared as Non-Collegiate. Less than 60% attendance will be declared as Dis-Collegiate. Non-Collegiate students may be allowed to appear in Final Examinations with a stipulated fine to the college whereas Dis-Collegiate students cannot appear in Final Examinations.

### **INFRASTRUCTURAL FACILITIES :**

- **Central Library**  
The Central Library of the college contains a spacious reading hall for teachers and students. Till now, more than 7,000 textbooks and reference books of different subjects are available. In due course, more books will be purchased.
- **Laboratory Facilities**  
Each department of the college has well-furnished and well-equipped laboratories and being upgraded day by day for the benefit of the students.
- **Smart Classrooms**  
At present there are four smart classrooms in the college which provide advanced teaching-learning process and mechanisms.
- **Hostel Facilities**  
There is a girls' hostel in the college campus with the capacity of 68 students.
- **Sports and Gymnasium**  
The college contains various sports equipments like cricket, football, volleyball, badminton, table tennis etc. The well-equipped gymnasium of the college is set up for the benefit of the students.

- **Boys' and Girls' Common Rooms**

The college provides separate Boys' and Girls' common rooms with necessary amenities.

- **Health Centre**

There is a health centre available in the college campus for emergency.

- **SCHOLARSHIP :**

Students of the college can avail various scholarships on fulfilling the eligibility norms. Some of them are

- a. National Scholarship.
- b. State Merit Scholarship.
- c. Post Matric Scholarship (for students belonging to ST, SC, OBC and MOBC categories).
- d. Scholarship for Minority students.

#### **ACADEMIC AND CO-CURRICULAR ACTIVITIES :**

- **Excursion and Field Trip**

The various departments of the college organise regular excursions and field trips for the students to gain firsthand experience and collect data in the concerned subjects both in HS and FYUGP courses.

- **Remedial Classes**

Different departments of the college have provisions of remedial classes and tutorial classes for the weak students based on their performance in unit tests and sessional examinations. ●

- **Annual College Week**

In order to encourage all-round development of the students, the Annual College Week is organised every year by the college where students get exposure to excel in sports, cultural and other co-curricular activities.

#### **GENERAL RULES FOR STUDENTS' CODE OF CONDUCT :**

Great emphasis is laid on discipline and character building of student and they are expected to maintain a high standard of discipline. They are subject to the rules and regulations of the College and Hostels. Students must carry their Identity cards and produce when necessary. The college authority should be intimidated in case of loss or damage of the Identity Cards. Moreover, involvement in the followings will be punishable if found guilty:

- a. Violation of rules, unsatisfactory progress, irregular attendance, irregular clearance of college and hostel fee.
- b. Discourtesy to the teachers and staff members in any form.
- c. Adoption of unfair means during examination.
- d. The college campus is strictly a "No Smoking"/ "No Alcohol" zone.
- e. Mobile phones and other electronic gadgets are prohibited inside the classrooms.
- f. Ragging in any form will lead to punishment of the students indulged in by the college authority, as per the directives of the Supreme Court.
- g. Damage of college property, spitting, writing and sticking bills on the college walls will be punishable.
- h. Any form of sexual harassment should be reported to the college authority in written in the 'Sexual Harassment Complaint Box'.
- i. Student Societies and Associations shall be subject to such rules and regulations as the college authority may prescribe from time to time. Only those Societies and Associations recognized by the college authority shall have the facilities of the College premises.



## **IMPORTANT INFORMATION TO PARENTS/ GUARDIANS :**

- a. Parents/ Guardians should kindly cooperate with the college authority to ensure the better performance of the students.
- b. Parents/ Guardians are requested to attend the Parents' Meets or any other college functions/programmes organised by the college authority.
- c. Parents/Guardians are requested to monitor the progress of the students at home and provide adequate facilities for study.

## **REGULATION FOR FYUGP UNDER NEP- 2020 :**

The institution is following the FYUGP under NEP-2020 as adapted by Gauhati Univesity form August, 2023. So for details, please refer to the regulations for Four Year UG-programme (FYUGP) of Gauhati University approved by academic council.

## **DIFFERENT COMMITTEES AND CELLS :**

### **1. IQAC**

- Chairperson : Dr. Navajyoti Sarmah, Principal
- Co-ordinator : Dr. Rupam Kalita
- Teacher-Representatives : Debajit Rabha, Dr. Upama Boruah
- Member from the Management : Dr. Malina Devi Rabha, Ex. Principal, Bikali College & President, Governing Body
- Senior Administrative Officers : Bhaskar Jyoti Barman, Maimoon Hoque, Krishna Kanta Ray, Samarjit Rabha

#### **Nominees (one from each):**

- Local Society : Robindra Nath Roy
- Students : Samudra Jyoti Rabha, General Secretary, Students' Union
- Alumni : Hrishikesh Brahma
- Employers : Gobinda Giri Ray.
- Industrialists : Mr. Rinku Daimary
- Industrialists : Mr. Amal Khakalary
- Stakeholders : Mr. Anjan Rabha

### **2. Admission Committee**

- Convenor : Dr. Navajyoti Sarmah, Principal
- Members : All HoDs
- Non-Teaching staff Members : Bhaskar Jyoti Barman, Maimoon Hoque, Nitumoni Nath, Paramanand, Rabha, Niranjana Keleng, Krishna Kanta Ray

### **3. Academic Committee**

- Convenor : Dr. Navajyoti Sarmah, Principal
- Jt. Convenor : Dr. Hari Prasad Gautam
- Members : All HODs, Coordinator, IQAC

### **4. Grievance Redressal Cell**

- Convenor : Dr. Navajyoti Sarmah, Principal
- Jt. Convenor : Dr. Hari Prasad Gautam
- Teacher Members : Debajit Rabha, Dr. Kshirod Sarmah, Dr. Chandrama Sarkar

### **5. Women's Cell**

- Convenor : Dr. Insan Ara Rahman,
- Joint Convenor : Dr. Chandralekha Dekka
- Teacher Members : Dr. Binita Das, Dr. Sudipta Phukan, Dr. Chandrama Sarkar, Sarah Lalsiemrem Pulamte, Dr. Kabyashree Phukan, Jyotimala Das.
- Non-Teaching staff Members : Jutika Rabha

## **6. Anti-Ragging Cell**

- Chairperson : Dr. Navajyoti Sarmah, Principal
- Faculty Representative : Dr. Rupam Kalita
- Student Guardian : Mr. Brajesh Sing, Mr. Rintu Pathak, Mrs. Rashmi Rabha
- Student : Mr. Debajit Nath
- Non Teaching Staff : Mr. Nitumoni Nath

## **7. Research Development Cell**

- Convenor : Dr. Rupam Kalita
- Teacher Members : Dr. Chandralekha Deka, Dr. Sudipta Phukan, Dr. Binita Das, Dr. Md. Shahidul Islam Khan, Monuj Bhuyan, Dr. Rajdeep Ghosh.

## **8. Extension Activities Cell**

- Convenor : Dr. Navajyoti Sarmah, Principal
- Jt. Convenor : Dibendu Handique
- Teacher Members : Dr. Mukul Kalita, Monuj Bhuyan, Dr. Jwngsar Daimari, Anuradha Kumari, Sudip Deb.
- Non-Teaching staff Members : Samarjit Rabha

## **9. Placement Cell**

- Convenor : Dr. Sangeeta Deka
- Members : Dr. Sisir Kr. Rajbongshi, Dr. Upama Baruah, Daisy Singha, Dr. Himasnata Dutta Sarkar, Er. Maimoon Hoque, Niranjana Keleng

## **10. Library Development Cell**

- Convenor : Dr. Navajyoti Sarmah, Principal
- Members : Ankita Salai, Dr. Hari Prasad Gautam, Dr. Insan Ara Rahman, Dr. Rupam Kalita, Er. Maimoon Hoque.

## **11. Sports Affairs**

- Convenor : Dr. Mukul kalita
- Teacher Members : Dr. Prasanta Gogoi, Dr. Monamohan Rabha, Monuj Bhuyan, Mubasara Yesmin, Chandana Rajkhowa, Arpita Choudhury
- Non-Teaching Staff Members : Samarjit Rabha, Bijit Das, Suman Sarmah, Niranjana Keleng, Jutika Rabha, Kangkan Basumaraty, Paramananda Rabha.

## **12. Disaster Management Cell**

- Convenor : Dr. Navajyoti Sarmah, Principal
- Jt. Convenor : Dr. Shahidul Islam Khan
- Teacher Members : Dr. Sisir kumar Rajbongshi, Dibendu Handique, Sabnoor Yearin Jyoti, Pooza Sharma, Rukmini Dolley, Jaba Kalita, Barnali Thakuriya

## **13. Institution's Innovation Council**

- Vice-president : Dr. Kshirod Sarmah
- Convenor : Dr. Upama Baruah
- Innovation Activity Co-ordinator: Dr. Mukul Kalita
- Start-up Activity Co-ordinator : Dr. Sangeeta Deka
- Internship Co-ordinator : Dr. Mana Mohan Rabha
- IPR Activity Co-ordinator : Dr. Chandrama Sarkar
- Social Media Co-ordinator : Dr. Upama Baruah
- ARIIA Co-ordinator : Dr. Shahidul Islam Khan
- NIRF Co-ordinator : Dr. Insanara Rahman
- NISP Co-ordinator : Dr. Mukul Kalita
- YUKTI Co-ordinator : Dr. Rupam Kalita
- Members : Ms. Sarah Lalsiemrem Pulamte, Mr. Dharmeswar Tarang, Ms. Sabnoor Yeasrin Jyoti, Mr. Bhaba Jyoti Das

#### **14. Prospectus, Academic Calendar and Class Routine Preparation Committee**

- Advisor : Dr. Navajyoti Sarmah, Principal
- In-Charge : Dr. Shahidul Islam Khan
- Teacher Members : Dr. Hari Prasad Goutam, Dr. Sisir Kumar Rajbongshi, Dr. Sudipta Phukan, Dibendu Handique, Shubhalikha Boruah

#### **15. Internal Compliant Committee:**

- Convenor : Dr. Navajyoti Sarmah, Principal
- Presiding Officer : Dr. Chandrama Sarkar
- Members : Dr. Kshirod Sarma,
- Non-Teaching staff Members : Bhaskar Jyoti Barman, Jutika Rabha
- Extnal Member : Nabanita Nath ( Advocate)
- Student Member : Miss Nupur Rajbongshi

#### **16. Unnat Bharat Abjiyan :**

- Coordinator : Dibendu Handique
- Teacher Members : Mr. Monuj Bhuyan, Dr. Mukul Kalita, Dr. Sangeeta Deka, Dr. Rajdeep Ghose
- Non-Teaching staff Members : Mr. Bijit Das, Mr. Nitumoni Nath

#### **17. NSS Unit Advisory Committee:**

- Chairman : Dr. Navajyoti Sarmah, Principal
- Programme Officer : Dr. Kshirod Sarmah
- Assistant Programme Officer : Mr. Bhabajyoti Das
- Teachers Member : Dibendu Handique. Dr. Awarlin Chetia
- Member : Dr. Prabin Rabha, MBBS, SDM & HO, Rangjuli BPHC
- Member : BDO, Kushdhowa Dev. Block

#### **18. NISP Implementation Expert Committee**

- President : Dr. Navajyoti Sarmah, Principal
- Vice President : Dr. Upama Baruah
- Convenor : Dr. Mukul Kalita
- Internal Member : Dr. Rupam Kalita, Dr. Sisir Kumar Rajbongshi, Dr. Shahidul Islam Khan, Dr. Dibyajyoti Kakoti, Dr. Sangeeta Deka, Mr. Bhabajyoti Das

#### **19. Media Circle**

- President : Dr. Navajyoti Sarmah, Principal
- Secretary : Mr. Monuj Bhuyan
- Members : Dibendu Handique, Dr. Sudipta Phukan, Rukmini Dolley

#### **20. RTI Cell :**

- Chairman : Dr. Navajyoti Sarmah, Principal
- PIO : Dr. Hari Prasad Gautam
- APIO : Mr. Bhaskar Jyoti Barman

#### **21. Gender Sensitization Committee :**

- Chairman : Dr. Navajyoti Sarmah, Principal
- Convener : Dr. Binita Das
- Member: : Dr. Manamohan Rabha, Manuj Bhuyan, Dibendu Handique
- Student Member : Nipon Jyoti Pathak

#### **22. Committee for SC/ST**

- Chairman : Dr. Navajyoti Sarmah, Principal
- ST Representative : Dr. Manamohan Rabha
- ST Representative : Samarjit Rabha
- SC Representative : Rajesh Kumar Das

#### **23. Minority Cell**

- Charman : Dr. Navajyoti sarmah, Principal
- Minority Representative : Dr. Shahidul Islam Khan, Dr. Insan ara Rahman, Sabnoor Yeasrin Jyoti

**24. OBC Cell:**

- Chairman : Dr. Navajyoti Sarmah, Principal
- OBC Representative : Dr. Sangeeta Deka
- OBC Representative : Dibendu Handique
- OBC Representative : Bhaskar Jyoti Barman

**25. ECO Club:**

- Chairman : Dr. Navajyoti Sarmah, Principa
- Teacher convenor : Dr. Sangeeta Deka
- Member : Dr. Mukul Kalita
- Member : Dr. Manamohan Rabha
- Member : Krishna Kanta Ray
- Students' Member : General Secretary Students Union

**26. Eletrol Literacy Club :**

- Nodal Officer : Dr. Dibya Jyoti Kakoti
- Member Secretary : Dharmeswar Tarang
- Member : Khanjan Kumar Nath, Rashi Mani Taulkdar, Jay Prakesh Nath, Pankaj Barman, Gracy Riksime N Areng

**27. Budget & Planning Committee :**

- President : Dr. Navajyoti Sarmah, Principal
- Vice President : Dr. Hari Prasad Gautam
- Member : Coordinator IQAC, All HoDs

**28. Cultural & Literary Cell ;**

- Chairperson : Dr. Navajyoti Sarmah, Principal
- Convenor : Dr. Binita Das
- Jt. Convenor : Dr. Dibya Jyoti Kakoti
- Member : Monuj Bhuyan, Dr. Awarline Chetia, Daisy Singha, Anuradha Kumari, Jutika Rabha

**29. Vikshit Bharat@2047**

- Chairperson : Dr. Navajyoti Sarmah, Principal
- Nodal Officer : Dr. Dibya Jyoti Kakoti
- Member : Vice-Principal, Coordinator IQAC, Bijit Das

**30. Hostel Management Committee**

- Chairperson : Dr. Navajyoti Sarmah, Principal
- Secretary : Warden Girls & Boys Hostel
- Member : Dr. Hari Prasad Gautam, Nitumoni Nath, Niranjana Keleng, Julius Hazowary

**31. Examination Committee**

- Chairperson : Dr. Navajyoti Sarmah, Principal
- Member Secretary : Vice-Principal
- Member : All HoDs, Niranjana Keleng, Nitumoni Nath, Krishna Kanta Ray

**INFORMATION AND CONTACT NUMBERS**

Sl.No.	Name	Designation	Contact No
<b>ADMINISTRATIVE STAFF</b>			
1	Dr. Navajyoti Sarmah	Principal	9435849434, 9101187756
2	Dr. Hari Prasad Goutam	Vice Principal	9401803421/7002318878
<b>TEACHING STAFF, SCIENCE STREAM</b>			
1	Dr. Insan Ara Rahman	HOD, Botany	8486728054, 8787865729
2	Debojit Rabha	Assistant Prof, Botany	7002073239
3	Dr. Sangeeta Deka	Assistant Prof, Botany	9706739361
4	Sabnoor Yeasrin Jyoti	Assistant Prof, Botany	8811889146

5	Dr. Chandrama Sarkar	Assistant Prof., Chemistry	9101375386
6	Dr. Prasanta Gogoi	Assistant Professor, Chemistry	8638763108
7	Dr. Upama Baruah	HoD, Chemistry	9954095908
8	Dr. Mukul Kalita	Assistant Prof., Chemistry	9678613061
9	Dr. Kshirod Sarmah	Assistant Prof., Computer Science	9101927881
10	Dr. Sisir Kumar Rajbongshi	Assistant Prof., Computer Science	9707721185
11	Dharmeswar Tarang	HoD, Computer Science	8812081299
12	Dr. Rajdeep Ghosh	Assistant Prof., Computer Science	7002590352 / 9085577988
13	Dr. Shahidul Islam Khan	HoD, Mathematics	9577480322, 7002820165
14	Rajesh Kumar Das	Assistant Prof., Mathematics	7002730635
15	Sudip Deb	Assistant Prof., Mathematics	8473895806
16	Jaba Kalita	Assistant Prof., Mathematics	6003016353
17	Dr. Rupam Kalita	Assistant Prof., Physics	8638184845, 8011193579
18	Dr. Mana Mohan Rabha	HoD., Physics	9678134549
19	Dr. Dibyajyoti Kakoti	Assistant Prof., Physics	
20	Dr. Chandralekha Deka	HoD, Zoology	8638572773, 9577712382
21	Bhabajyoti das	Assistant Prof., Zoology	9101433694, 8414967456
22	Dr. Awarlin Chetia	Assistant Prof., Zoology	7629951153
23	Dr. Kabyashree Phukan	Assistant Prof., Zoology	8724057808
<b>TEACHING STAFF, ARTS STREAM</b>			
1	Dr Binita Das	Assistant Prof, Assamese	8638948717
2	Dibendru Handique	Assistant Prof, Assamese	8011778841, 9101016869
3	Monuj Bhuyan	HoD, Assamese	6001875632
4	Dr. Sudipta Phukan	HoD, English	8638839245
5	Sarah Lalsiemrem Pulamte	Assistant Prof., English	9678335785
6	Rukmini Dolley	Assistant Prof., English	9395063295
7	Anuradha Kumari	Assistant Prof., Economics	9365145458
8	Mubashra Yesmin	Assistant Prof., Education	7896248969
9	Dr. Barnali Thakuria	Assistant Prof., Education	7002791047
10	Dr Jwngsar Daimari	Assistant Prof., History	9531186168
11	Pooza Sharma	Assistant Prof., History	6001283733
12	Shubhalikha Boruah	Assistant Prof., Political Science	9810873109
13	Jyotimala Das	Assistant Prof., Political Science	9435513061
14	Chandana Rajkhowa	Assistant Prof., Political Science	7002724744
15	Daisy Singha	Assistant Prof., Sociology	801186709
16	Dr Himasnata Dutta	Assistant Prof., Sociology	9706340702
17	Dr. Arpita Choudhury	Assistant Prof., Sociology	8473820430
<b>LIBRARY STAFF</b>			
1	Ankita Saloi	Librarian	8638582636
2	Maimoon Hoque	Assistant Librarian	9957860533, 8486947804
<b>NON-TEACHING STAFF</b>			
1	Bhaskar Jyoti Barman	Office Assistant	9864941816, 8638483448
2	Bijit Das	Laboratory Bearer	7002016252
3	Jutika Rabha	Laboratory Bearer	8473088914
4	Niranjan Keleng	Laboratory Bearer	7002695851
5	Suman Sarma	Office Bearer	9954684710, 7002149592
6	Krishna Kanta Ray	Office Bearer	9678102074
7	Nitu Moni Nath	Office Bearer	8876699630
8	Kanakan Basumatary	Office Bearer	7896885574
9	Parama Nanda Rabha	Office Bearer	8473848537
10	Samarjit Rabha	Office Bearer	9706438031, 7002015493

## ACADEMIC CALENDER FOR THE ACADEMIC SESSION 2024-2025

MONTHS	WORKING DAYS	SUNDAYS	HOLIDAYS		COLLEGE ACTIVITIES
End of July, 2024	Completion of Admission Process		for all UG Programmes		
August 2024	1,2,3,5,6,7,8,9,10,12,13,14,16,17,19,20,21,22,24,27,28,29,30,31	4,11,18,25	15 23 26	Independence Day Tithi of Sri Sri Madhab Dev Janmastomi	<ul style="list-style-type: none"> <li>Commencement of UG classes for odd Semesters;</li> <li>Fresher's Social</li> </ul>
September 2024	2,3,5,6,7,9,10,11,12,13,14,16,17,18,19,20,21,23,24,25,26,27,28,30	1,8,15,22,29	4	Tithi of Sri Sri Sankardev	<ul style="list-style-type: none"> <li>Odd Semester Sessional Examinations</li> </ul>
October 2024	1,3,4,5,7,8,19,21,22,23,2,25,26,28,29,30.	6,13,20,27	2 1-18 31	Birthday of Mahatma Gandhi Durga Puja, Lakshmi Puja, Janmostav of Srimanta Sankardev, Kati Bihu Kali Puja	<ul style="list-style-type: none"> <li>Unit Test (I) for HS 1st Year</li> <li>Unit Test (II) for HS 2nd Year</li> <li>Field Trip (Subject specific)</li> </ul>
November 2024	2,4,5,6,8,9,11,12,13,14,16,18,19,20,21,22,23,25,26,27,28,29,30	3,10,17,24	1 3 7 15 24	Dewali Bhatri Dwitiya Chhat Puja Guru Nanak's Birthday Lachit Divas	<ul style="list-style-type: none"> <li>Last Week: Conduct of Examinations for UG Courses</li> </ul>
December 2024	1,3,4,5,6,7,9,10,11,12,13,14,16,17,18,19,20,21,23,24,26,27,28,29,31	1,8,15,22,29	2 25	Asom Divas (Sukafa Divas) Christmas Day	<ul style="list-style-type: none"> <li>Last Week: Commencement of UG classes for odd Semesters;</li> <li>Test Examinations for HS 1st and 2nd Year</li> </ul>
January 2025	1,2,3,4,6,7,8,9,10,11,16,17,18,20,21,22,23,24,25,27,28,29,30,31	5,12,19,26	Other holidays and academic activities from January, 2025 to onwards will be notified by the College Authority in due time as per GU Academic Calendar and holiday list		<ul style="list-style-type: none"> <li>Commencement of Even Semester classes;</li> <li>Annual College Week;</li> <li>Unit Test (II) for HS 1st Year</li> </ul>
February 2025	1,3,4,5,6,7,8,10,11,12,13,14,15,17,18,19,20,21,22,24,25,26,27,28	2,9,16,23			<ul style="list-style-type: none"> <li>HS 2nd Year Final Examination</li> </ul>
March 2025	1,3,4,5,6,7,8,10,11,12,13,14,15,17,18,19,20,21,22,24,25,26,27,28,29,31	2,9,16,23,30			<ul style="list-style-type: none"> <li>HS 1st Year Final Examination</li> <li>Sessional Examinations for Even Semesters</li> </ul>
April 2025	1,2,3,4,5,7,8,9,10,11,12,14,15,16,17,18,19,21,22,23,24,25,26,28,29,30	6,13,20,27			
May 2025	1,2,3,5,6,7,8,9,10,12,13,14,15,16,17,19,20,21,22,23,24,26,27,28,29,30,31	4,11,18,25			<ul style="list-style-type: none"> <li>First Week: Conduct of Examinations for UG Courses</li> </ul>
June 2025	2,3,4,5,6,7,9,10,11,12,13,14,16,17,18,19,20,21,23,24,25,26,27,28,30	Summer Term (Period of internship for students who would like to exit after completion of certificate programme under FYUGP.			
July, 2025	1st July-31st July-- Summer Vacation				

- N.B**
- Dates of Unit Tests and Sessional Examinations will be notified in due course of time.
  - Date of Winter Break to be notified by the College authority as per G.U. Academic Calendar.

## মহাবিদ্যালয় সঙ্গীত

নতুন নতুন মাহ, আহিল নতুন মাহ  
আমাৰ বহল বুঝুতে ।  
বগলীৰে বগা পাখি ডিহলিৰে আবশ্যতে,  
জগ-জগৰ চিহ্নাঙু আমাৰ আপোন হাতে ॥

মৰা সঁতিৰ ধল আনো শুবন শুবন মাটিতে  
সমাজৰে পিটনিতে মাটি ঢালো বঙতে ।  
পঢ়া-শুনাৰ চাৰিটিৰে, জ্বলালো উলাহতে  
জেউজীয়া আপোন আঁবেশ, ডিলমিল জেউতিতে ॥

হেজৰ মুগৰ একাৰে, আঁতৰাম নিজ হাতে  
একআৰে আগবাঢ়ো, জেউতিৰে বাটে বাটে ।  
সূৰ্যৰে ধেমালি, বাঙলী চোতালতে  
পূৰণিৰে গাত নাচে নতুনে উলাহতে ॥

ৰচনা : ড০ ভূপেন হাজৰিকা



Prospectus, Academic Calender and Class Routine  
Perparation Committee

### COLLEGE UNIFORM

#### Boys :

**Trouser :** Formal-White  
(Low Waist Jeans and Trousers are not allowed)

**Shirt :** Formal-Purple & White Checks  
(Short shirts with different collars are not allowed)

#### Girls :

**Kurta :** Purple & White Checks

**Salwar :** White

**Dupatta :** White

D. No. 35528

